

Practice for Final Exam

Student **FULL** Name: _____

Lab Section: _____

Write your FULL name (the same as how you put in the system) as CLEAR as possible!

You are allowed two 8.5" × 11" sheets of prepared notes, a pen or pencil, and a calculator. No internet connected devices are allowed. Write legibly. For maximum credit, state all assumptions and show all work in a clear manner.

Problem #	Points Possible	Points Earned
1	8	
2	22	
3	10	
4	15	
5	22	
6	18	
Submission	5	

Problem 1: Circle the correct answer (8 pts, 2 pts x 4)

a) For the inductor defined on the right, which equation is correct:

A. $i_L = L \frac{dv_L}{dt}$ B. $v_L = L \frac{di_L}{dt}$

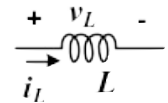

b) For the capacitor defined on the right, which equation is correct:

A. $i_C = C \frac{dv_C}{dt}$ B. $v_C = C \frac{di_C}{dt}$

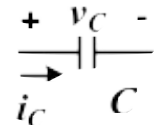

c) For the black box on the right with given current and voltage, the box is:

A. Developing power B. Absorbing power

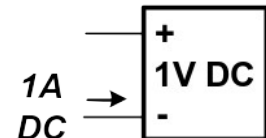

d) Which of the circuits below represents negative feedback and more likely to be used for linear operation?

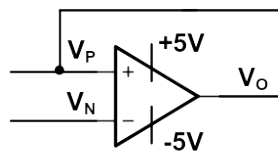

A

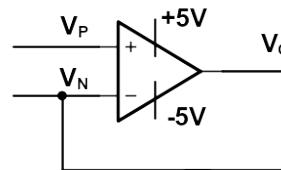

B

Problem 2: Op-amp circuits (22 pts)

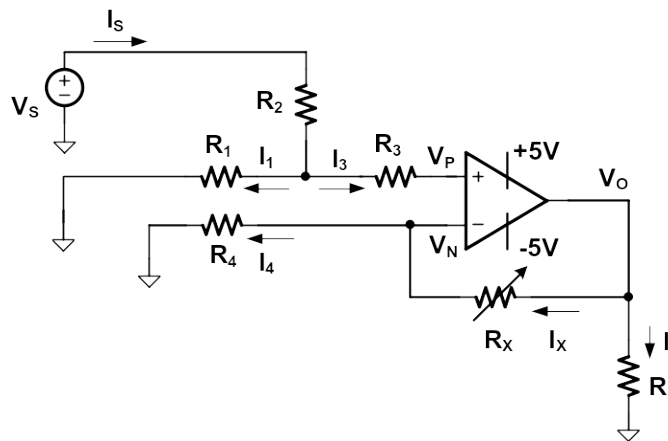

For the above circuits, assume ideal Opamp and linear operation. R_x is a variable resistor and can be adjusted. All elements: V_s , R_1 , R_2 , R_3 , R_4 , R_L , R_x , have known values. The supply voltages for the opamp are 5V and -5V.

- a) How much is I_3 ? [1 pt]
- b) Will R_L affects the V_O (Note that the Opamp is ideal)? [1 pt]

- c) Find the voltage equation for V_P (you don't need to plug in values yet). [3 pts]
- d) Find the gain equation for $A_V = V_O/V_S$. [10 pts]
- e) The parameters have values of: $V_S=2V$, $R_1=R_2=2k\Omega$, $R_3=R_4=1k\Omega$, $R_X=0\Omega$. Calculate V_O . [2 pts]
- f) With other parameters the same as in e), adjust R_X and find the maximum possible R_X while maintaining linear operation for the Opamp. [5 pts]

Problem 3 RL Response: (10 pts)

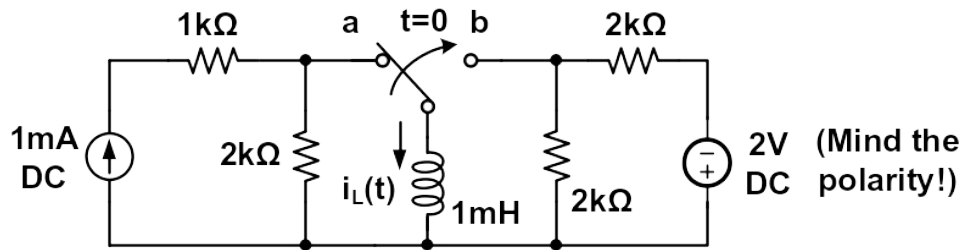

The switch stays at position “a” for a very long time. At $t=0$, it switches to “b”.

- Find the initial condition of $i_L(0^+)$. [2 pts]
- Find the final condition of $i_L(t)$ when t approaches ∞ . [2 pts]
- Find the time constant τ of the circuit for $t \geq 0^+$. [2 pts]
- Find the full equation of $i_L(t)$ for $t \geq 0$. [4 pts]

Problem 4: RLC circuits (15 pts)

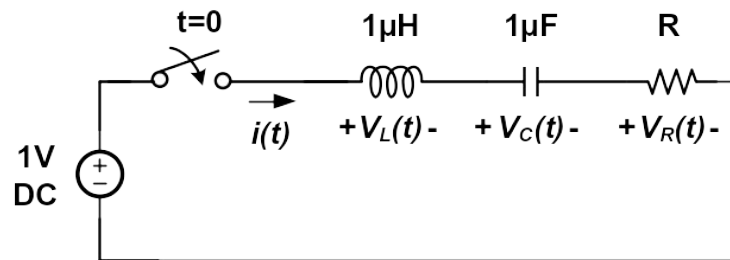

The initial energy stored in the inductor and capacitor is zero. The switch was open before $t=0$ for a long time. At $t = 0$, the switch closes and a 1V DC voltage source is attached to the circuit.

We know for series RLC circuit: $\alpha = \frac{R}{2L}$, $\omega_0 = \frac{1}{\sqrt{LC}}$.

a) Find the R value for critical damping. (5 pts)

b) What will be initial voltage of $V_L(0^+)$, $V_C(0^+)$ and $V_R(0^+)$, immediately after the switch closes (6 pts)

c)

d) If R is larger than the value calculated in a), the circuit will be in (Circle the correct answer): (2 pts):

- A. Under-damped condition;
- B. Over-damped condition;
- C. Critical-damped condition.

e) If R is larger than the value calculated in a), (Circle the correct answer) (2 pts):

- A. Ringing will happen;
- B. The response will still be smooth but will settle slower, without ringing.

C. The response will still be smooth but will settle faster, without ringing.

Problem 5: Frequency Domain Circuit Analysis (22 pts)

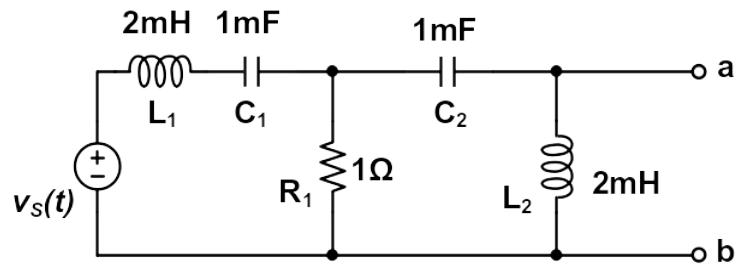

In the above circuits, $v_s(t) = 2 \cos 1000t$.

a) Convert the inductors and capacitors into impedance. (6 pts)

b) Find the Thevenin Equivalent voltage \vec{V}_{TH} in the frequency domain, then convert it back to the time domain $V_{TH}(t)$. (8 pts)

c) Find the Thevenin Equivalent impedance Z_{TH} . (5 pts)

- d) In order to extract the maximum real power from the source, find the loading impedance that should be attached between “a” and “b”. (3 pts)

Problem 6: Complex Power (18 pts)

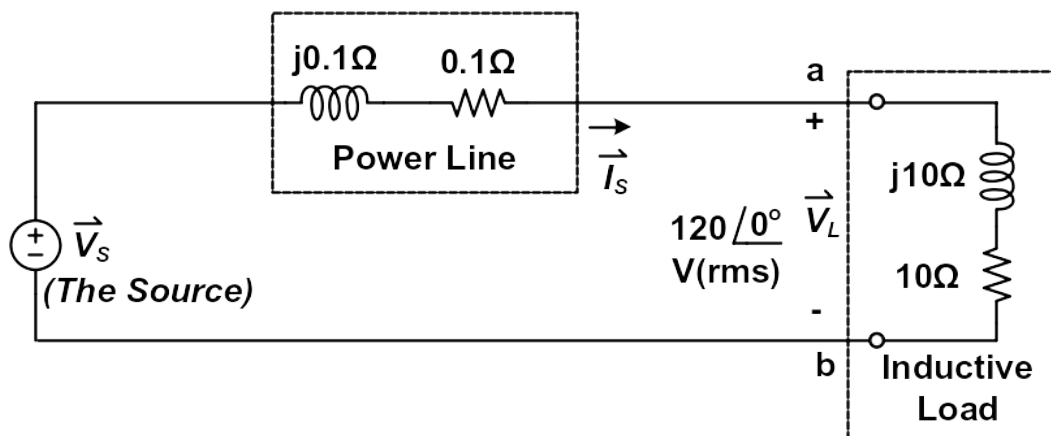

In the above circuit, an inductive load is attached between terminals “a” and “b”. The power line also has finite impedance. The loading now sees an AC voltage V_L of 120V rms with 0° phase angle. (All the voltages and currents in this problem are in **rms** or **effective** values.)

- a) Find the current phasor \vec{I}_s . (2 pts)

b) Find the complex power (including average power and reactive power) and power factor of the **Load**. (6 pts)

c) Find the average power dissipated by the **power line**. (4 pts)

d) Find the complex power delivered by **the source**. (6 pts)